

**INSTRUCTIONS FOR USE:** 70-123 V06 050221

## **StepByStep-I und III, 02901, 02904, 02905, 02993, 02994, 02997, 02998. Step III, 02941, 02942.**

### **Intended use:**

This desk/table has been designed exclusively for use in schools and is therefore intended solely for this purpose. Any other use that goes beyond the intended purpose (e.g. in workshops, storage areas or damp locations) is classed as not in accordance with the intended use. The company VS Vereinigte Spezialmöbelfabriken GmbH & Co. KG shall not be held liable for damage arising from such non-intended use.

### **General note on reading and storing the instructions:**

Please read these instructions and in particular the notes on safety carefully and in full before using the products. Keep the instructions in a safe place for subsequent reference and pass them on to other users.

### **General note on safety:**

We use the following symbols and notes in our assembly instructions:

 **Caution!** This symbol refers to an important note on assembly.

### **On the internet:**

Alternatively, they can be downloaded: (see header title).

### **Standardize:**

Tested according to DIN EN 1729 Part 1 + 2, size class 2 to 7.

### **Scope of delivery:**

The product is delivered fully assembled.

### **Operation:**

Follow the instructions on the following page.

### **Troubleshooting and service:**

If faults occur, please contact our Aftersales Service [kundenservice@vs-moebel.de](mailto:kundenservice@vs-moebel.de)

### **Maintenance and Cleaning:**

On the internet: [vs.de/kataloge/reinigung/en](http://vs.de/kataloge/reinigung/en)

### **Forwarding and Disposal:**

If the product is passed on to any third party then these instructions must be supplied with it. Please contact your relevant local authority for information on environmentally compatible disposal.

The indicated electric and electronic components must not be disposed of with the ordinary waste.

They must be removed from the furniture unit before the unit is sent for disposal. They are to be disposed of at authorized collection and return points.



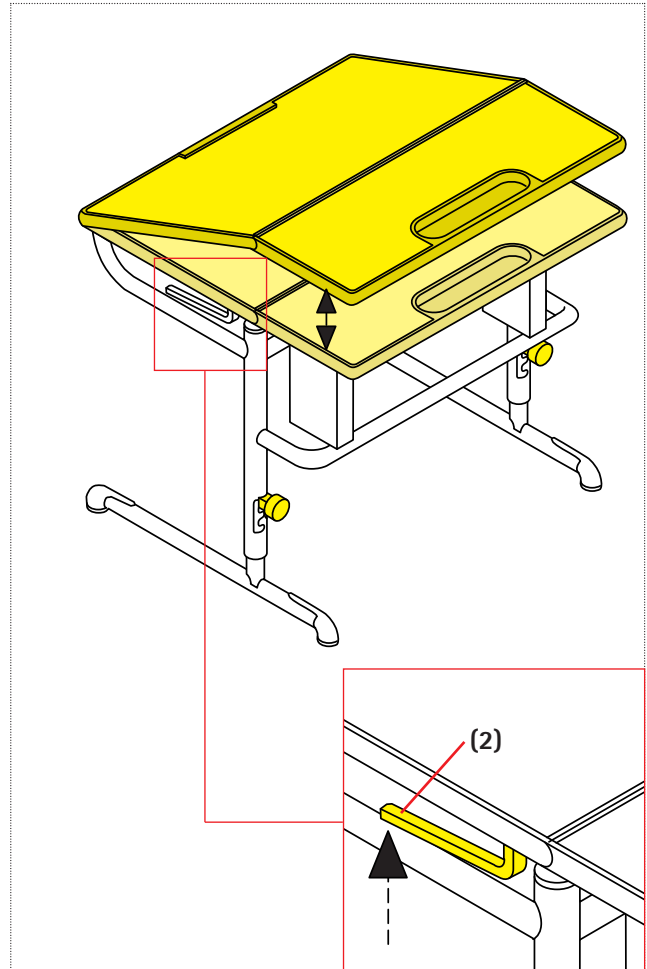
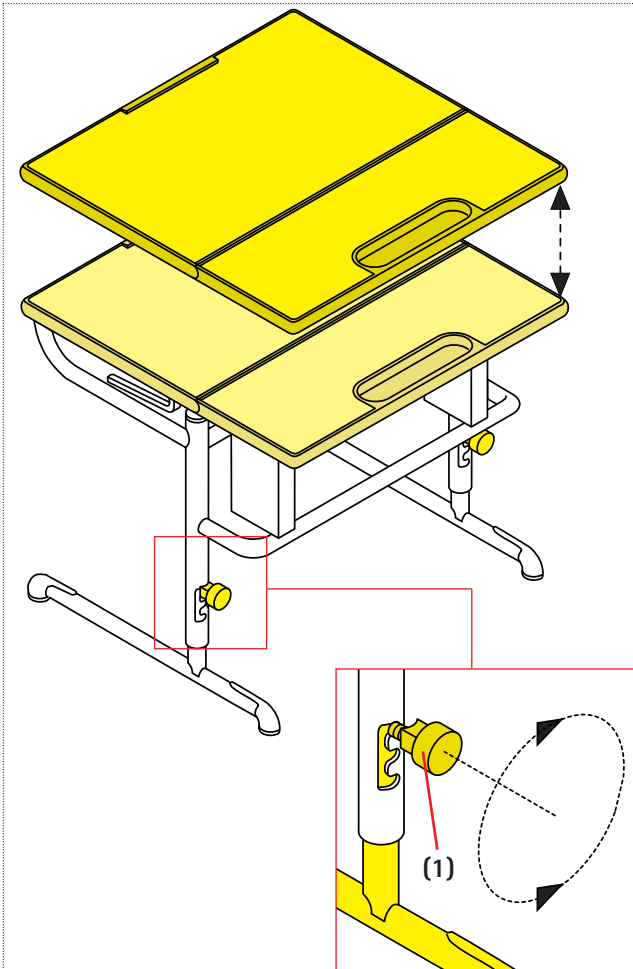

### 1. Adjusting the table height (for StepByStep)

The height can be adjusted in steps: 53; 59; 64; 71; 76; 82 cm, size 2 to 7. There are three basic height settings, each of which has three fine adjustments.

- Depending on the model, loosen the locking screw (Allen key, size SW 5) or hand wheel (1).
- Release the table skid from the catch and adjust to the top or bottom position (see scale).
- Insert the table skid into the catch again.
- Secure using the locking screw or hand wheel (1).

### 2. Basic height adjustment (for StepByStep)

- Screw out the locking screw or hand wheel (1).

#### **! Caution! -- Child safety mechanism --**

1. Screw the hand wheel out of the thread (turns without engaging),
2. Turn the hand wheel towards you until the second threaded section engages
3. Screw out completely.

- Position the table skid vertically at the required height (see scale).
- Secure using the locking screw or hand wheel (1).

### 3. Adjusting the table top, only for models 02941, 02942, 02997, 02998

- Angle of inclination adjustable in steps:
- 4 0°; 5°; 10°; 16°; 20°.

- Press the release lever (2) (on the pupil's side on the right and left below the table top) upwards (towards the table top) and hold it in place.
- Move the table top sideways and adjust it to the required angle of inclination.
- It engages at the different available levels of adjustment.

### 4. With rollers (optional)

The table top must be empty before the table is moved. Only empty tables may be wheeled in this way. To prevent damage to the rollers, do not wheel the tables over door sills or uneven surfaces.

**! Caution!** Only lift the table slightly as there is otherwise a danger it may tip over.

Slightly lift by users.

